



Power Factor Optimization with Cos Phi Mode Trainee

Aziz Yulianto Pratama¹, Dieta Wahyu Asry Ningtias², Dani Usman³, Purwandito Tulus Asmoro⁴, Feri Siswoyo Hadisantoso⁵

¹Indorama Engineering Polytechnic, Purwakarta, Indonesia. Email aziz@pei.ac.id

²Indorama Engineering Polytechnic, Purwakarta, Indonesia. Email dieta@pei.ac.id

³Indorama Engineering Polytechnic, Purwakarta, Indonesia. Email dani.usman@pei.ac.id

⁴Indorama Engineering Polytechnic, Purwakarta, Indonesia. Email purwandito@pei.ac.id

⁵Indorama Engineering Polytechnic, Purwakarta, Indonesia. Email feris.siswoyo.h@pei.ac.id

Corresponding Author Email aziz@pei.ac.id

Abstract. The power factor $\cos \phi$ measures the efficiency of using electrical power in a system. A low power factor indicates the presence of high reactive power consumption, which can lead to increased energy losses and operational costs. To overcome this problem, an effective power factor regulation system is required. This research designed and developed the Cos Phi Trainer, which operates in two modes, manual and automatic, to improve the power factor at an electrical load. The system is designed to give users a practical understanding of measuring and improving power factors by setting up compensation capacitors. In manual mode, the user directly sets the value of the capacitor used to fix the power factor. While in automatic mode, the system uses current and voltage sensors to measure the power factor value in real-time and automatically adjusts the capacitor to achieve the optimal power factor. The trainer has an easy-to-use interface and a measurement panel that displays important parameters such as current, voltage, active power, reactive power, and power factor. The test results show that the system can significantly increase the power factor in manual and automatic modes. Thus, this Cos Phi Trainer is an effective tool for training in the laboratory of Indorama Engineering Polytechnic and teaching about electrical power management and energy loss reduction in the electrical system.

Keywords: Power factor, manual, active power, reactive power, trainer

INTRODUCTION

Non-linear loads can be found in household electrical appliances such as televisions, computers, air conditioners (AC), lights, irons, and others (Abrianto & Facta, 2023)(Alafghani, 2023). The load has a winding element or coil of wire that can cause harmonics and voltage imbalances. This can degrade power quality and increase reactive power (Davira et al., 2024)(Hunaini et al., 2023). Deterioration in power quality can cause disruptions to the electrical system and reduce energy efficiency (Fernando et al., 2023). Meanwhile, increasing reactive power can be detrimental to customers economically. This is because reactive power is power that is absorbed or not used for charging but still has to be paid by the customer, so

solutions are needed to improve power quality to minimize these losses (Lestari et al., 2021). The improvement in power quality must be based on the power quality standards or power factors set by the State Electricity Company (PLN), above 0.85 (Harahap Raja, 2023). If it is in accordance with the standards, then customers will be well-served, and electrical equipment or electronic goods will be quickly damaged. Based on this, power quality needs to be considered, especially in household loads. Previous studies have been conducted on improving power quality. The power quality can be improved in various ways, such as using compensators, multi-inverters, capacitors, and high-efficiency electronics. Compensators can enhance power quality at unbalanced loads (Roy et al., 2023). Deterioration in power quality due to voltage harmonics can be reduced using multi-inverters (Vijayvargiya et al., 2023). The use of capacitors is the most common solution to improve power quality. In addition, there is also research related to the manufacture of power quality monitoring tools. Power quality is monitored to observe the value of $\cos\phi$ or power factor to be analyzed for follow-up treatment (Wahyudi et al., 2023). This research designed a tool that can improve power quality. The tool is in the form of a trainer that can monitor the effect of capacitor addition on power quality improvement. Capacitors were chosen in this study because they can reduce reactive power, improve voltage profiles, and improve network stability (Rezapour et al., 2024)(Rahman et al., 2022)(Ivascanu et al., 2024). The research is focused on designing trainers with manual and automatic modes. Manual mode is where the user selects the capacitor value by himself, while automatic mode is the program in which the trainer selects the capacitor value automatically based on the best power factor repair value. The trainer can read the voltage, current, energy, active power, and power factor values. Then the results of the power factor improvement can be analyzed.

METHODS

The research uses a quantitative method to improve the $\cos\phi$ value or power factor. The main components of the capacitor are used to repair the $\cos\phi$. The trainer operates in two modes: manual and automatic.

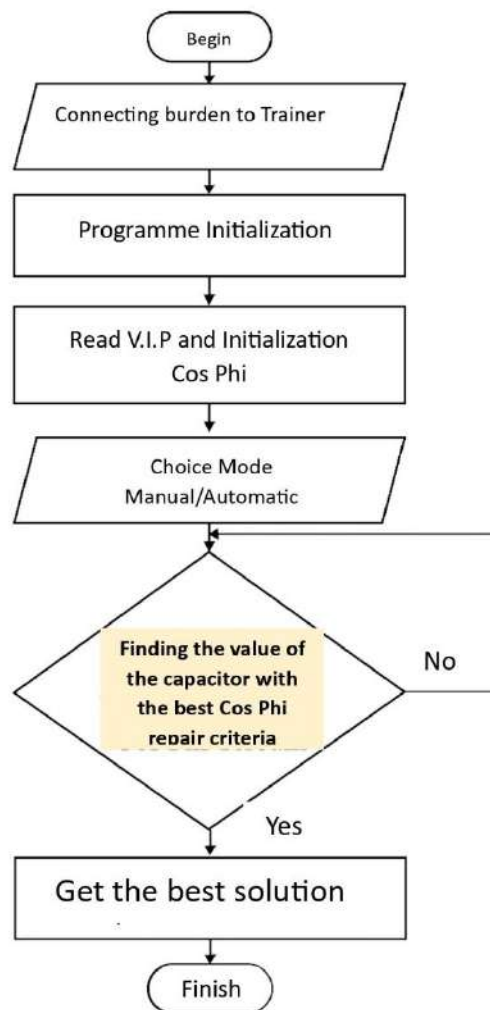

Figure 1. Cos Phi Trainer Operating Flow Chart

Figure 1 shows the operation of the trainer in correcting the cos phi value or power factor with the following grooves or steps:

- a. Connecting the load to the trainer.
The load used is a one-phase load on the household, namely the Tube Luminescent lamp (TL lamp) and the fan, which are tested alternately.
- b. Program initialization.
The Arduino microcontroller carries out program initialization with the intention of determining the variables used.
- c. Read V, I, P, f, and cos phi.
The trainer reads the initial values of voltage (V), current (I), active power (P), frequency (f), and cos phi or power factor. The initial value is the initial variable before the capacitor is added.
- d. Find the value of the capacitor using the best cos phi repair criteria.
In manual mode, the user selects the capacitor value available in the trainer.

In automatic mode, the microcontroller automatically selects the best capacitor value. The Arduino program searches for the value of the capacitor size (μF) that affects the result of the $\cos \phi$ repair. The largest $\cos \phi$ improvement will be a reference in selecting the capacitor size.

- e. Get the best $\cos \phi$ results with the recommended capacitor size or value.

Power Factor Improvements

The trainer's main goal is to improve the $\cos \phi$ score. According to PLN standards, $\cos \phi$ is 0.85; to approach this value, this study uses the reference range of the desired new $\cos \phi$ values of 0.7, 0.8, and 0.9. New $\cos \phi$ values can be obtained by adding capacitors. The capacitor can reduce the reactive power of the load absorption, improving the power factor value. (Alfikri et al., 2023) (Lestari et al., 2020).

The value of the capacitor to be used to fix the $\cos \phi$ can be obtained through the following formulation:

The circuit is calculated first using the initial values of voltage (V), current (I), frequency (f), and $\cos \phi$ or power factor. Then, the active power value (P) is obtained in equation (1).

$$P = V \cdot I \cdot \cos \phi \tag{1}$$

After obtaining the initial, we look for new values to improve the power factor. In this study, the reference values of the desired new $\cos \phi$ are 0.7, 0.8, and 0.9. After obtaining the value, the current value can be calculated in equations (2) and (3).

$$I_1 = \frac{P}{V \cdot \cos \phi_1} \tag{2}$$

$$I_2 = \frac{P}{V \cdot \cos \phi_2} \tag{3}$$

After obtaining the current value, the apparent power can be obtained in equations (4) and (5).

$$S_1 = V \cdot I_1 \tag{4}$$

$$S_2 = V \cdot I_2 \tag{5}$$

The obtained current can also be used to calculate the reactive power value in equations (6) and (7).

$$Q_1 = V \cdot I_1 \cdot \sin \phi_1 \tag{6}$$

$$Q_2 = V \cdot I_2 \cdot \sin \phi_2 \tag{7}$$

After getting the value, the compensation value or power compensation (Q_c is the difference in reactive power between before and after capacitor addition) can be obtained through equation

$$Q_c = Q_1 - Q_2$$

$$Q_c = Q_2 - Q_1 \quad (8)$$

After obtaining the information, it is possible to determine the value of the capacitor (C) to be used, as obtained through equation 9. $Q_c C$

$$C = \frac{Q_c}{-(V^2 \cdot 2\pi f)} \quad (9)$$

Description =

ϕ_1 = initial phase angle before capacitor addition ($^\circ$)

ϕ_2 = final phase angle after capacitor addition ($^\circ$)

$\cos \phi_1$ = power factor before capacitor addition

$\cos \phi_2$ = power factor after capacitor addition

C = Capacitor (μF)

f = frequency (Hz)

I_1 = Initial current before capacitor addition (A)

I_2 = New current after the addition of capacitors (A)

V = Voltage (V)

P = Active Power (Watts)

S = Apparent Power (VA)

Q = Reactive Power (VAR)

Mechanical and Electrical Planning

Mechanical Planning

Mechanical design can be a 3-dimensional design used as a reference in realizing the tool. (Komang & Riskiono, 2020) The Power Factor Repair Trainer frame stores all components in a storage box (suitcase) with a length of 46 cm, a width of 33 cm, and a height of 15 cm. Figure 2 shows the trainer design from the top and side, while Figure 3 shows the components found in the trainer.

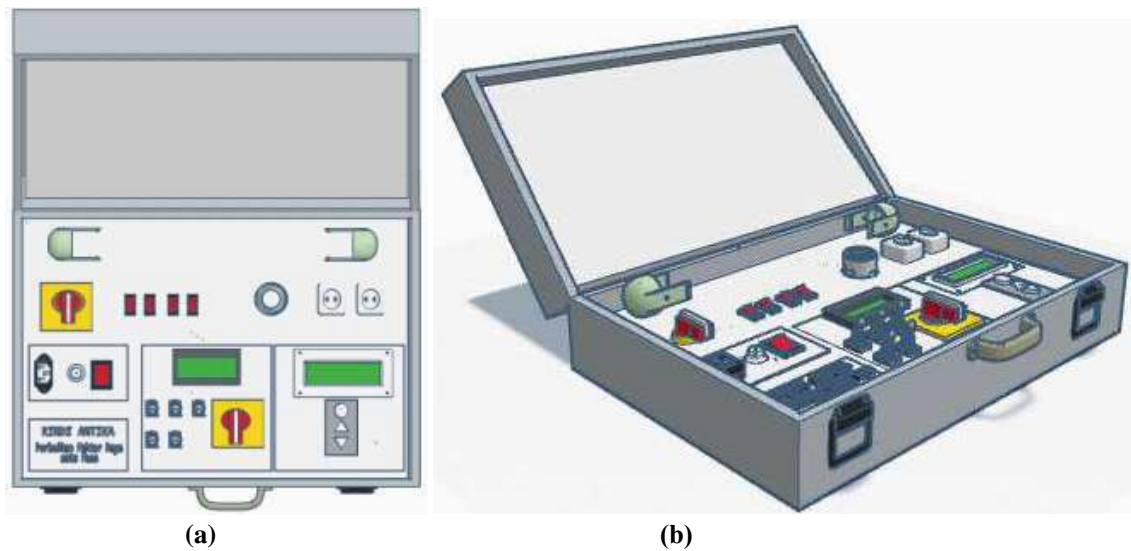

Figure 2. Trainer Design: (a) Top View, (b) Side View

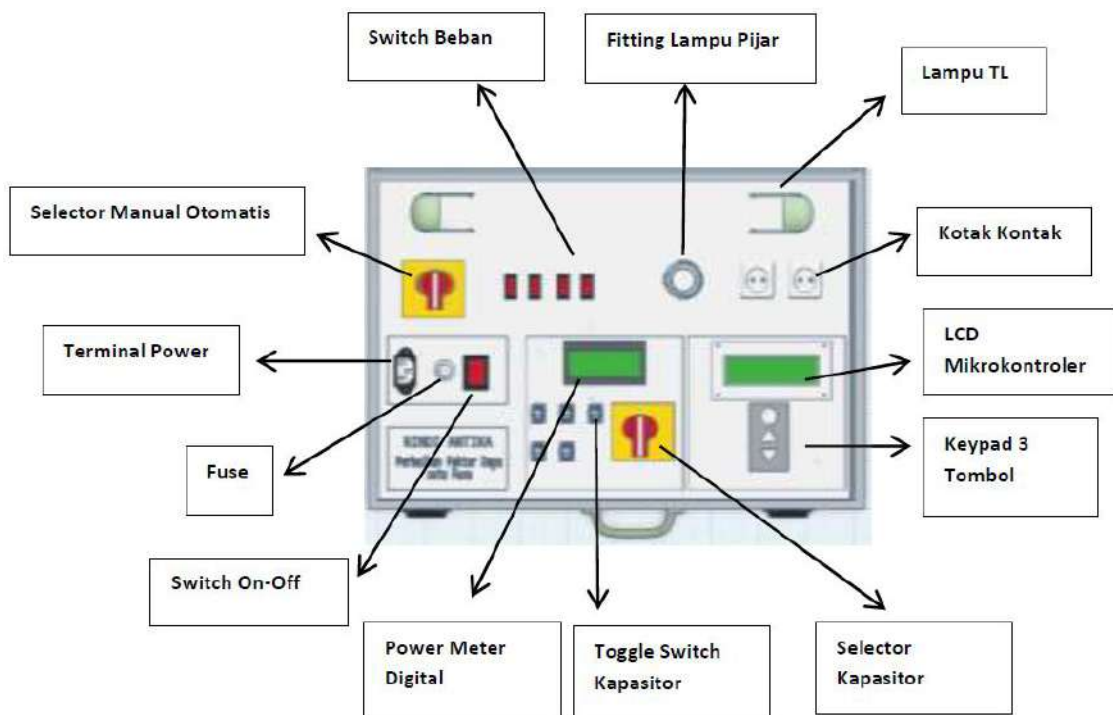

Figure 3. Components on the Trainer

Electrical Planning

Electrical design in the form of a picture of the electronic wiring of the trainer cos phi. Figure 4 is the electrical design used in this study.

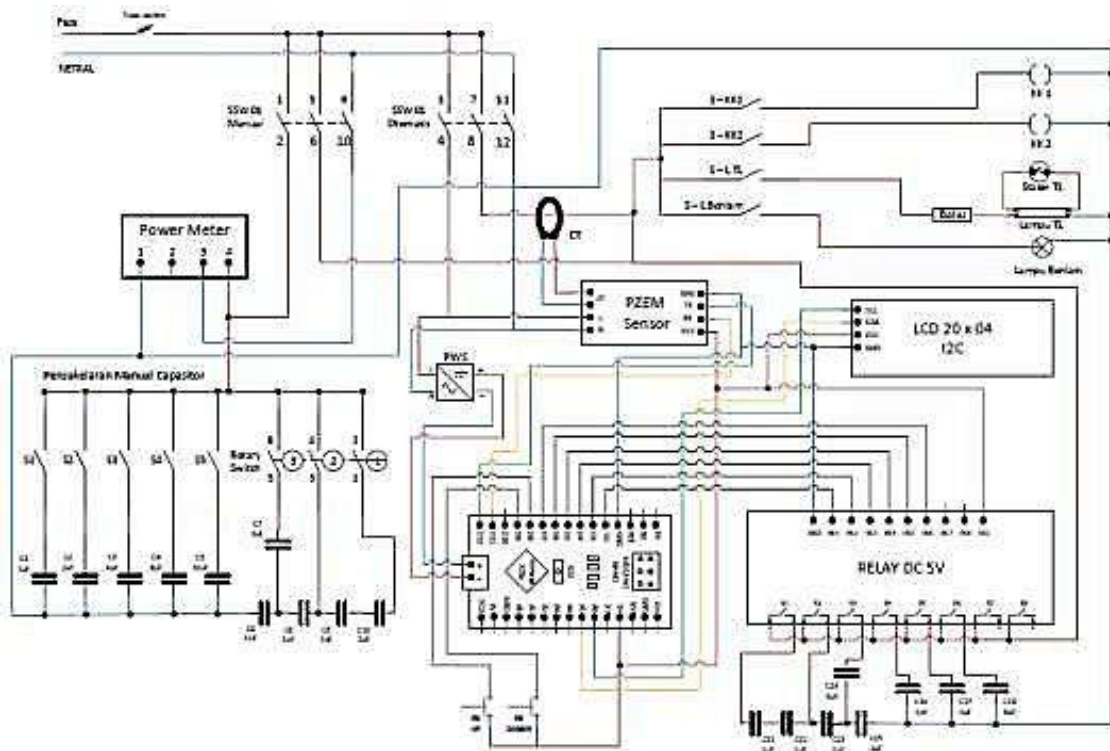

Figure 4. Cos Phi Trainer Electrical Planning

Explain the type and design of research (quantitative or qualitative) that has been carried out. An explanation of the research design can be supplemented with images, *flowcharts*, or charts. The research method also describes in detail the data source, data collection method (both primary and secondary), research object (population and sample or respondent), and data analysis. The research method and the research instruments used are also required.



Figure 5. Image using (Figure Caption style)

DISCUSSION

Power Factor Improvement Testing and Calculation

This test carried out several experiments, including manually testing the influence of inductive, resistive, and capacitive loads on the power factor.

Testing Against Inductive Loads

Testing Before Power Factor Repair on Manual Systems

This test was carried out using a manual system and a power meter. The TL lamp and fan use the inductive load. The main voltage source used is a 220V AC voltage source with a power capacity of 10W TL lights and a fan of 20W.



Figure 6 Measurement Results Before Power Factor Repair (a) TL Lamp: (b) Fan

Table 2 shows the measurement results of inductive loads using a power meter before the power factor improvement.

Table 2 Results of Inductive Load Measurement Before Power Factor Repair

It	Burden	V(V)	I(A)	f(Hz)	P(W)	Cos φ
1	TL Lights	208 V	0.14 A	50 Hz	12.05 W	0,42
2	Fan	205 V	0.09 A	50 Hz	9.81 W	0,54

Based on the measurement results before the power factor correction or before the addition of capacitors, a power triangle can be depicted using the following equation:

$$S1 = V \cdot I$$

$$S1 = 208V \cdot 0.14A \quad S1 = 29.12 \text{ VA}$$

$$P1 = V \cdot I \cdot \text{Cos } \phi \quad P1 =$$

$$12.05$$

$$Q1 = V \cdot I \cdot \text{Sin } \phi$$

$$Q1 = 208V \cdot 0.14A \cdot \text{Sin } 65.17^\circ \quad Q1 = 26.43$$

VAR

Calculation of Capacitor Requirements in Manual Systems

The following is a calculation of the need for capacitors for power factor repair and the need for capacitors with inductive loads in the form of TL lamps and fans.

Table 3 Calculation Result Data

It	Burden	Cos φ1	Cos φ2	Current (A)	Necessity Capacitor (uF)
1	TL Lights	0,42	0,7	0.84A	1.03 uF
		0,42	0,8	0.74A	1.27 uF
		0,42	0,9	0.65A	1.51 uF
2	Fan	0,54	0,7	0.69A	0.40 uF
		0,54	0,8	0.61A	0.61 Uf
		0,54	0,9	0.54A	0.81 Uf

Power Factor Repair Testing Against Inductive Load After Addition of Capacitors to Manual Systems

It is the data from measuring inductive loads using a power meter after the power factor is improved.

Table 4. Measurement Result Data After Power Factor Correction

It	Burden	Voltage (V)	Cos φ2	Installed Capacitors (uF)	I2 (A)	Cos φ Readable	Active Power (W)
1	Lamp TL	208V	0,7	1 uF	0.08A	0,69	11.93W
		209V	0,8	1.25 uF	0.07A	0,76	12.02W
		211V	0,9	1.5 uF	0.07A	0,86	12.38W
2	Fan Wind	206	0,7	0.5 uF	0.06A	0,75	9.85W
		202	0,8	0.5 uF	0,06	0,75	9.45W
		201	0,9	1 Uf	0,05	0,96	9.36W

Testing of Inductive Loads in Automated Systems

Table 5. Results of Automatic Measurement of Inductive Load Before Power Factor Repair

It	Burden	V(V)	I(A)	P(W)	Cos φ1	Cos φ 2	Necessity Capacitor (uF)
1	TL Lights	213,70	0,15	13,10	0,42	0,7	1,03
		211,50	0,14	12,70	0,42	0,8	1,26
		212,50	0,14	12,90	0,42	0,9	1,50
2	Fan	205,00	0,09	10,20	0,54	0,7	0,41
		207,10	0,09	10,30	0,54	0,8	0,61
		207,80	0,09	10,20	0,54	0,9	0,80

In the automatic system, after the measurement of capacitor needs is seen on the microcontroller LCD screen with a time interval (*delay*) of 3 seconds, then the power factor will be automatically corrected according to the required capacitor value. The following is a picture of the results of the measurement of power factor improvement on inductive loads after the automatic addition of capacitors.

Table 6. Results of Inductive Load Measurement After Power Factor Improvement

It	Burden	Cos φ Desired	Cos φ Measurabl e	Result Capacitor
1	TL Lights	0,7	0,69	(+) 0,03
		0,8	0,78	(+) 0,05
		0,9	0,86	(+) 0,10
2	Fan	0,7	0,74	(-) 0,08
		0,8	0,74	(+) 0,12
		0,9	0,96	(-) 0,14

From the data results in the table above, the measured Cos φ is not exactly the same as the desired Cos φ, because the value of the capacitor installed is not enough to meet the required capacitor value. For example, for the load of a TL lamp with a desired Cos φ of 0.7, but the measured one is only 0.69, which means that a capacitor of 0.03uF is still needed. The capacitor value of 0.03 is not readable because the capacitors installed start from 0.25uF

Testing Against Inductive, Resistive, and Capacitive Loads Manual System Testing

This test was carried out in two trials. The first experiment uses an inductive load in the

form of a TL lamp and a resistive load in the form of an incandescent lamp. The second experiment uses an inductive load in the form of a TL lamp and a fan with a resistive load in the form of an incandescent lamp and an iron.



Figure 7 Measurement of Inductive and Resistive Loads on Manual Systems
 (a) Experiment 1; (b) Experiment 2

The measurement results are the data from the measurements made using a power meter in experiments 1 and 2.

Table 7. Data on Inductive and Resistive Load Measurement Results in Manual Systems

It	Burden	V(V)	I(A)	F(Hz)	P(W)	Cos ϕ
1	TL Lights (Inductive Load)	207V	0.27A	50Hz	48.70W	0.88
	Incan descent Lamp (Resistive Load)					
2	TL Light	200V	1.65A	50Hz	329W	0.99
	Fan (Inductive Load)					
	Incandescent					
	Iron (Resitive Load)					

Based on the table above, experiment 1 has a Cos ϕ of 0.88, which can be catalyzed to have a good Cos ϕ because it is close to the value of 1. However, the author will try to improve the power factor to 0.9 and 0.95. For experiment 2, because it has a Cos ϕ of 0.99, there is no need

to improve the power factor.

Testing the trainer to the user

The role of this trainer as a learning medium is to facilitate students in the learning process and meet learning objectives. So, the author tested this trainer directly to users (electrical technology students) by providing learning materials about this trainer and then conducting direct practical socialization with this trainer. This testing activity was carried out for two days at the Electrical Technology Workshop.

The results of this test are poured into a questionnaire. The assessment elements in this test include trainer design, effectiveness of the relationship with teaching materials, validity, educational value, practicality, durability of tools, aesthetics, and motivation. The assessment categories in this questionnaire are 1 = disagree, 2 = somewhat agree, 3 = agree, 4 = strongly agree.

Table 8 Questionnaire Result Data

Elements	Questionnaire Results	Percentage										
Design Trainer	<p>Desain pada trainer sangat inovatif dan kreatif</p> <table border="1"> <tr><th>Response</th><th>Percentage</th></tr> <tr><td>1</td><td>0.0%</td></tr> <tr><td>2</td><td>0.0%</td></tr> <tr><td>3</td><td>6.25%</td></tr> <tr><td>4</td><td>93.75%</td></tr> </table>	Response	Percentage	1	0.0%	2	0.0%	3	6.25%	4	93.75%	<p>1 = 0%</p> <p>2 = 0%</p> <p>3 = 37.5%</p> <p>4 = 62.5%</p>
Response	Percentage											
1	0.0%											
2	0.0%											
3	6.25%											
4	93.75%											
Design Trainer	<p>Setiap bagian dari trainer ini berfungsi dengan baik</p> <table border="1"> <tr><th>Response</th><th>Percentage</th></tr> <tr><td>1</td><td>0.0%</td></tr> <tr><td>2</td><td>12.5%</td></tr> <tr><td>3</td><td>43.75%</td></tr> <tr><td>4</td><td>43.75%</td></tr> </table>	Response	Percentage	1	0.0%	2	12.5%	3	43.75%	4	43.75%	<p>1 = 0%</p> <p>2 = 6.3%</p> <p>3 = 43.8%</p> <p>4 = 50%</p>
Response	Percentage											
1	0.0%											
2	12.5%											
3	43.75%											
4	43.75%											
Effectiveness Linkages with materials teach	<p>Trainer ini dibutuhkan dalam proses pembelajaran mahasiswa teknologi listrik</p> <table border="1"> <tr><th>Response</th><th>Percentage</th></tr> <tr><td>1</td><td>0.0%</td></tr> <tr><td>2</td><td>0.0%</td></tr> <tr><td>3</td><td>6.25%</td></tr> <tr><td>4</td><td>93.75%</td></tr> </table>	Response	Percentage	1	0.0%	2	0.0%	3	6.25%	4	93.75%	<p>1 = 0%</p> <p>2 = 0%</p> <p>3 = 6.3%</p> <p>4 = 93.8%</p>
Response	Percentage											
1	0.0%											
2	0.0%											
3	6.25%											
4	93.75%											
Effectiveness Linkages with materials teach	<p>Trainer ini sesuai dengan materi pembelajaran yang ada di teknologi listrik</p> <table border="1"> <tr><th>Response</th><th>Percentage</th></tr> <tr><td>1</td><td>0.0%</td></tr> <tr><td>2</td><td>6.25%</td></tr> <tr><td>3</td><td>6.25%</td></tr> <tr><td>4</td><td>87.5%</td></tr> </table>	Response	Percentage	1	0.0%	2	6.25%	3	6.25%	4	87.5%	<p>1 = 0%</p> <p>2 = 6.3%</p> <p>3 = 6.3%</p> <p>4 = 87.5%</p>
Response	Percentage											
1	0.0%											
2	6.25%											
3	6.25%											
4	87.5%											
Effectiveness Linkages with materials teach	<p>Memudahkan mahasiswa dalam memahami materi perbaikan factor daya</p> <table border="1"> <tr><th>Response</th><th>Percentage</th></tr> <tr><td>1</td><td>0.0%</td></tr> <tr><td>2</td><td>6.25%</td></tr> <tr><td>3</td><td>18.75%</td></tr> <tr><td>4</td><td>75%</td></tr> </table>	Response	Percentage	1	0.0%	2	6.25%	3	18.75%	4	75%	<p>1 = 0%</p> <p>2 = 6.3%</p> <p>3 = 18.8%</p> <p>4 = 75%</p>
Response	Percentage											
1	0.0%											
2	6.25%											
3	18.75%											
4	75%											
Validity	<p>Data perhitungan dengan data hasil pengukuran menghasilkan nilai yang sesuai</p> <table border="1"> <tr><th>Response</th><th>Percentage</th></tr> <tr><td>1</td><td>0.0%</td></tr> <tr><td>2</td><td>6.25%</td></tr> <tr><td>3</td><td>25%</td></tr> <tr><td>4</td><td>68.75%</td></tr> </table>	Response	Percentage	1	0.0%	2	6.25%	3	25%	4	68.75%	<p>1 = 0%</p> <p>2 = 6.3%</p> <p>3 = 25%</p> <p>4 = 68.8%</p>
Response	Percentage											
1	0.0%											
2	6.25%											
3	25%											
4	68.75%											

CONCLUSION

1. Using Cos Phi Mode Trainer is an effective method to optimize the power factor in the electrical system. With this technology, monitoring, analysis, and adjustment of phase angle can be carried out to minimize reactive power and improve the efficiency of active power use. Implementing these optimizations contributes to energy savings, reduced operational costs, and reduced emissions resulting from energy waste. The trainer is also a helpful training tool in technical education, allowing users to understand the basic principles of power factors and their application on an industrial scale.
2. The design results of this practicum tool (Power et al.) can be used manually or automatically to improve household power factor, with the highest power factor correction of 0.95 from the lowest initial power factor of 0.42.
3. The capacitor can improve the power factor, especially for inductive loads that have a Cos ϕ well below the value of 1 and also, the inductive load itself consumes both active power and reactive power so that the capacitor can supply reactive power (VAR) to the inductive load

BIBLIOGRAPHY

- Arda, I. (2019, November). Trainer Development of the Electrical and Electronics Course as a Learning Media in Electrical Department SMKN 1 Tilatang Kamang. In *Journal of Physics: Conference Series* (Vol. 1387, No. 1, p. 012130). IOP Publishing.
- Fartino, N., Tarmizi, T., & Syukri, M. (2020). Study on the Design of Automatic Power Factor Repair Tools. *Journal of Computer, Information Technology, and Electricity*, 5(1).
- Feriyanti, R. V., Pratama, A. Y., & Novianto, D. (2022). Analysis of Temperature Monitoring System with LM35 Sensor Using OHP (Over Head Projector) Based on Raspberry Pi. *Journal of Applied Electrical Engineering*, 6(2), 43-47.
- Haditya, R., Syahputra, R., Chamin, A. N. N., Pratama, A. Y., & Rizky, W. Y. (2022). Analysis of the Effect of Load Sharing on Generators Using the Speed Drop Method at PLTU Suralaya. *Journal of Syntax Transformation*, 3(07), 964-972.
- Juliantara, P. A., Wijaya, I. A., & Partha, C. I. (2018). Design and build automatic bank capacitors based on ATmega 328P microcontrollers for power factor improvement. *SPECTRUM Journal*, 5(1), 157-163.
- Nuraini, N., & Badriana, B. (2018). Design for the Repair of TL Lamp Power Factor with Capacitors. *Journal of Electrical Energy*, 7(2), 11-15.
- Rizqi, M. B., Pangaribuan, P., & Suhendi, A. (2019). Design and implementation of smart switching in on-grid power supply systems. *eProceedings of Engineering*, 6(2)
- Santoso, I. H., Hartono, T. N., & Ir Mahfudz Shidiq, M. T. (2014). *Design of Household Load Power Factor Repair Tool Using Automatic Capacitor and Inductor Switching* (Doctoral dissertation, Brawijaya University).